

I. S. Roland.

Spoke Lathe.

No. 90,689.

Patented Jan. 1, 1869.

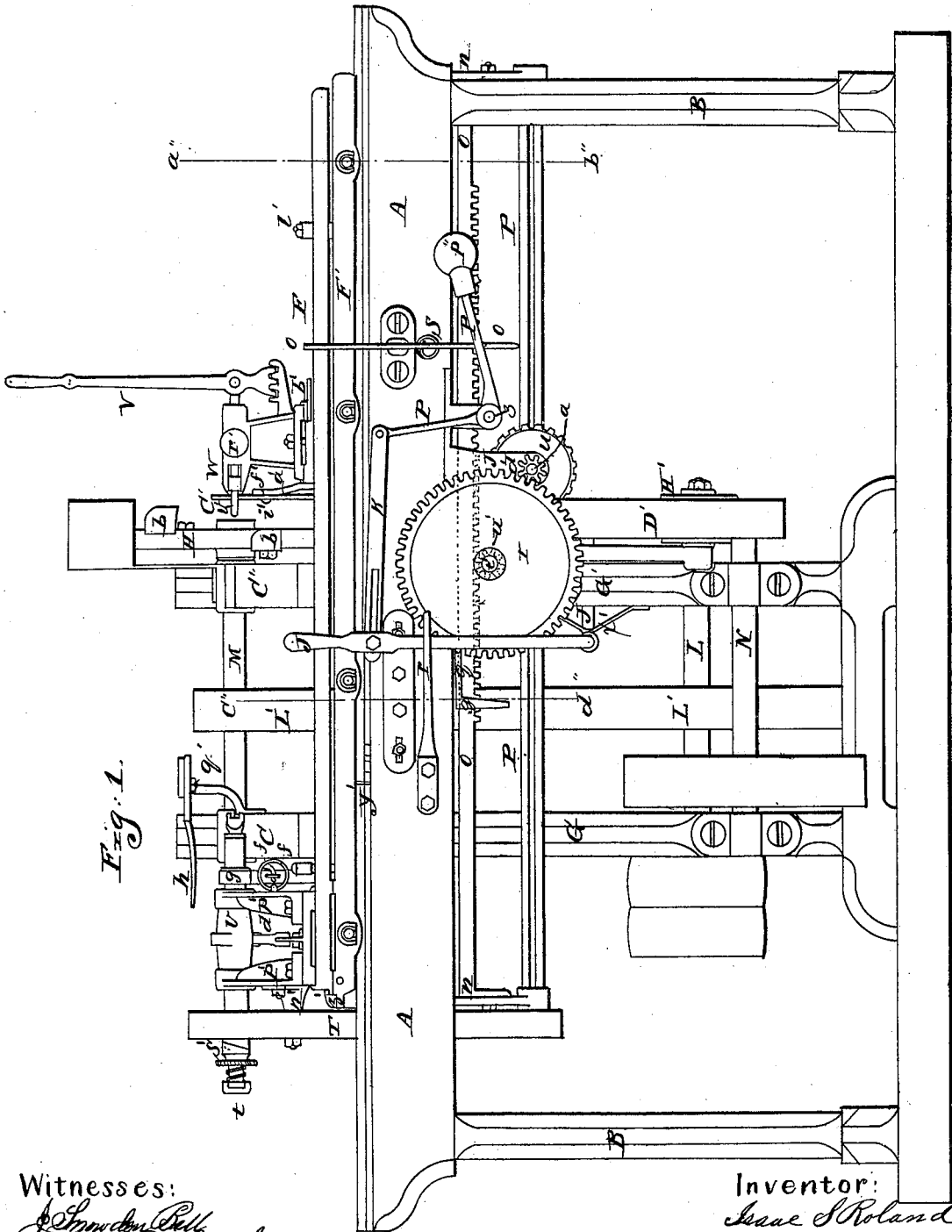

Fig. 1.

Witnesses:

Samuel Bell
Sydney E. Smith

Inventor:

Isaac S. Roland
By his attorney *J. C. Robbins*

I. S. Roland

Sheet 2-4, Sheets

Stroke Lathe

N^o 90,689.

Patented Jan. 1, 1869.

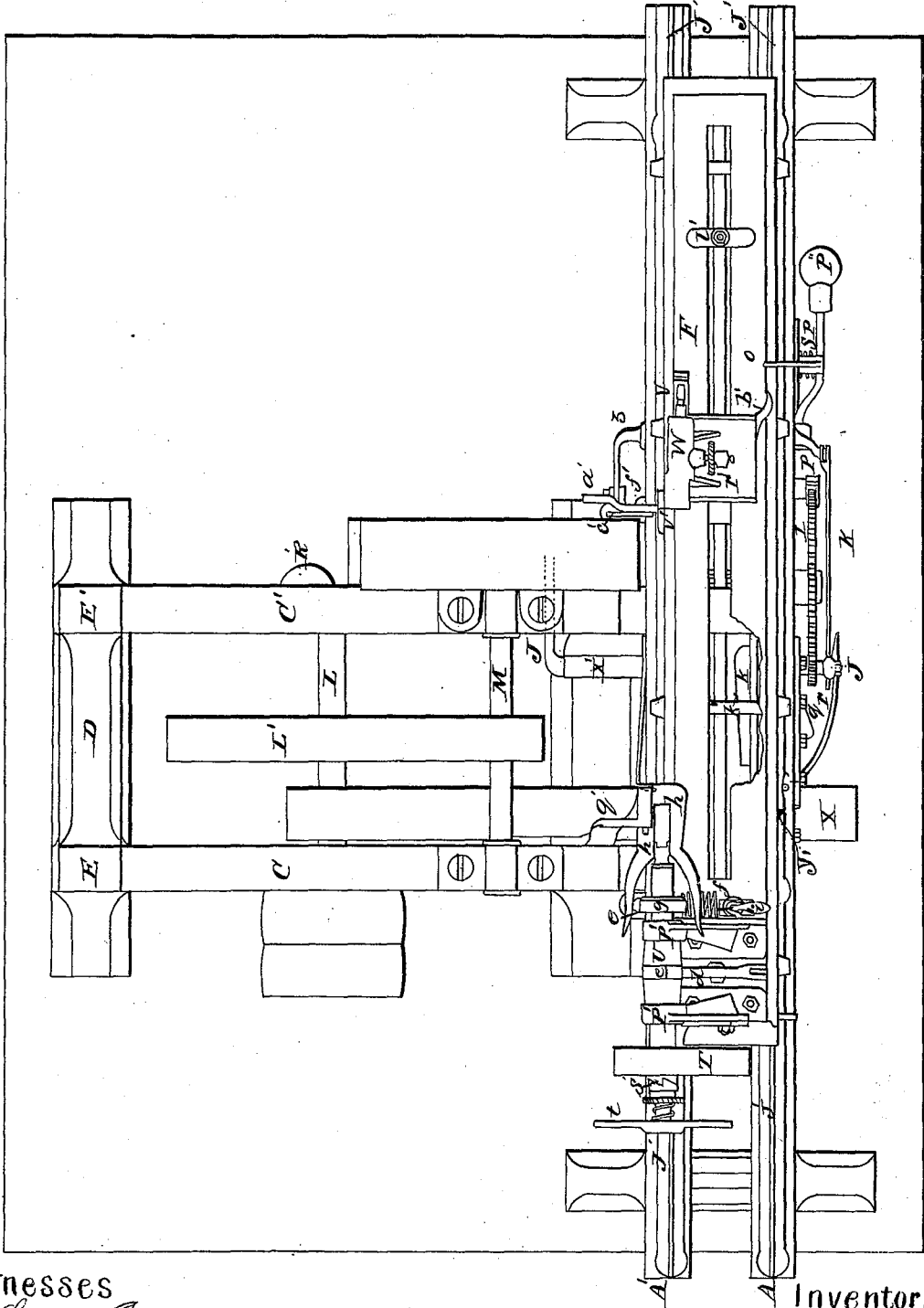

Fig. 2

Witnesses

A. Snowden
Sydney E. Smith

Inventor:

Isaac S. Roland
By his attorney J. C. Robbins

I. S. Roland Spoke Lathe.

N^o 90,689.

Patented Jan. 1, 1869.

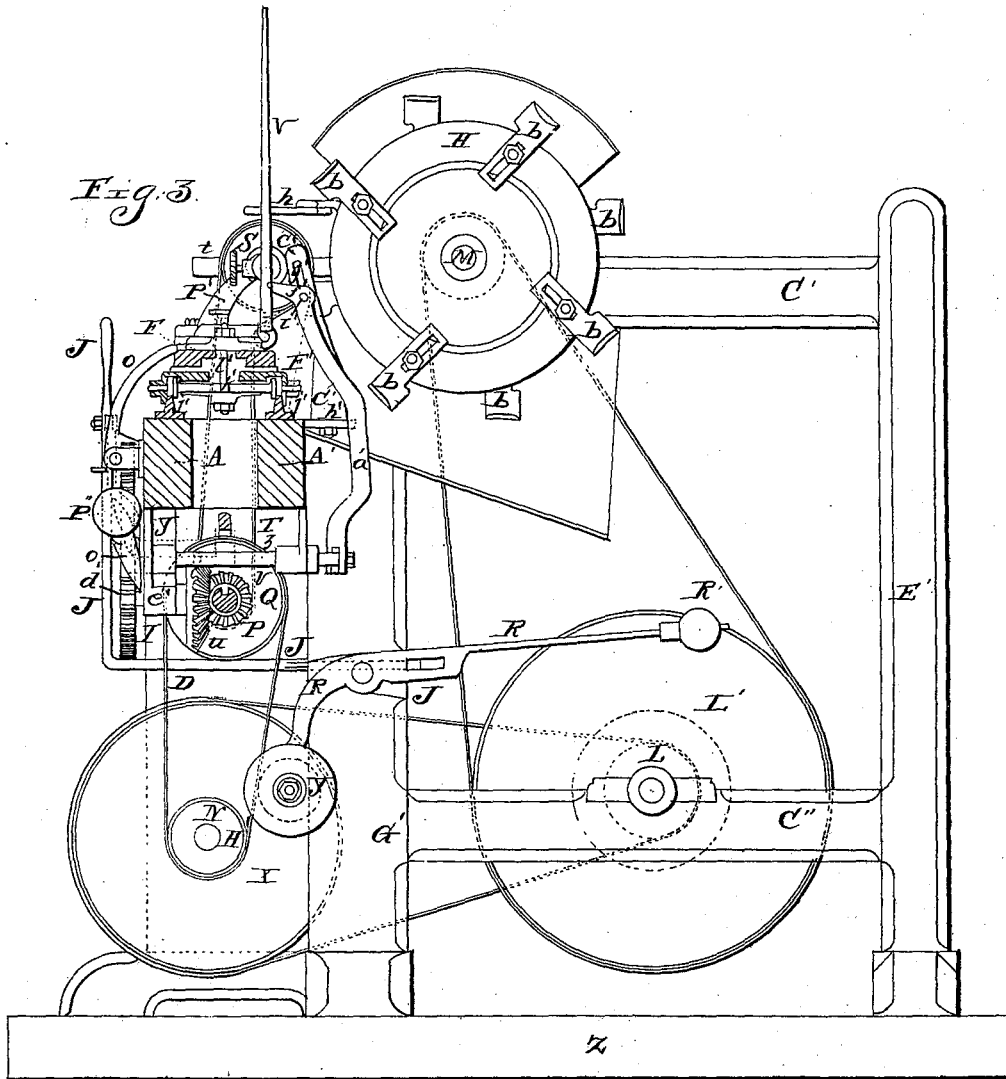

Witnesses:

J. Snowden Bell
Sydney C. Smith

Inventor:

I. S. Roland
 By his attorney
J. C. Robbins

I. S. Roland.

Sheet 4-4, Sheets.

Stroke Lathe.

No. 90,689.

Patented Jan. 1, 1869.

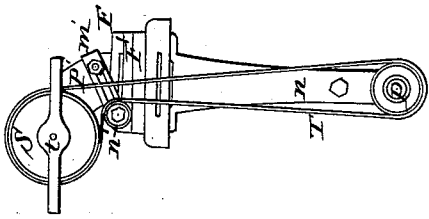

Fig. 9.

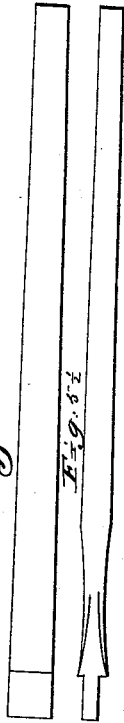

Fig. 5.

Fig. 5 1/2.

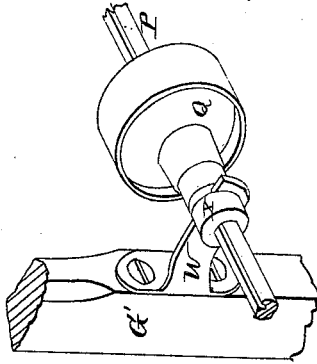

Fig. 8.

Fig. 10.

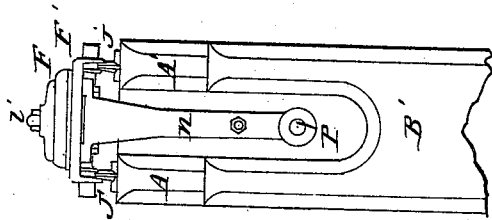

Fig. 7.

Fig. 11.

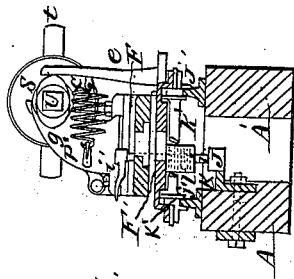
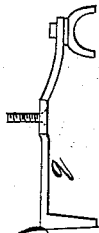
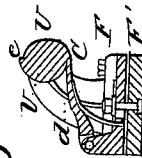

Fig. 4.

Fig. 6.



Witnesses:

J. Snowden Bell
Sydney E. Smith

Inventor:

Isaac S. Roland
By his attorney
J. C. Robbins

United States Patent Office.

ISAAC S. ROLAND, OF READING, PENNSYLVANIA.

Letters Patent No. 90,689, dated June 1, 1869.

IMPROVEMENT IN SPOKE-LATHE.

The Schedule referred to in these Letters Patent and making part of the same.

To all whom it may concern:

Be it known that I, ISAAC S. ROLAND, of Reading, in the county of Berks, and State of Pennsylvania, have invented a new and improved Spoke-Lathe; and I do hereby declare that the following is a full and exact description thereof, reference being had to the accompanying drawings, which constitute a portion of this specification.

Figure 1 is a front elevation of said lathe;

Figure 2, a top view;

Figure 3, a transverse section in the line $a'' b''$ of fig. 1; and

The other drawings represent various parts of the machine in detail.

The nature of my invention consists in the peculiar combination and arrangement of the respective parts of my improved spoke-lathe, by which I am enabled to automatically form a perfect spoke, substantially in the manner hereinafter particularly set forth.

The front portion of the frame-work, which supports the respective parts of my improved spoke-lathe, is composed of the horizontal parallel beams $A A'$, and the forked side-posts $B B'$, the said beams being firmly secured to the respective forked terminations of said posts, as shown in Figure 7.

The rear portion of the supporting-frame of my improved spoke-lathe, is composed of the front vertical posts $G G'$, the rear posts $E E'$, and the connecting-beams $C, C', C'',$ and D , as shown in figs. 1, 2, and 3.

The bearing-rails $j j$, secured to the upper sides of the parallel beams $A A'$, receive and support the carriage F' , which carries the chucks and all the machinery required for supporting the spoke-blank, and imparting the requisite movements thereto whilst it is being operated upon by the cutters $b b$ in the rotating cutter-head H .

The chuck-carrier F rests upon suitable transverse bearings, which rise from the face of the carriage F' , and is secured thereto by means of the pivot l , near the right-hand end thereof, and by the lip z , which rises from the extreme left-hand end of the carriage, and embraces a ledge at that end of the chuck-carrier, as shown in fig. 1.

The arms $p p'$, which rise from near the left-hand end of the chuck-carrier F , receive and support the arbor U of the chuck or mandrel.

The base of the carrier W , of the centre-chuck v , rests upon the chuck-carrier F , and its shape is such that it can be secured in any desired position upon the said carrier F , by means of a set-screw.

When a spoke-blank has been secured between the head-chuck or mandrel on the arbor U and the centre-chuck v , and the requisite rotary motion has been imparted thereto, the oval shape of the portion g of the arbor U of the head-chuck, and its peculiar combination with other parts of the lathe, causes the rotary

motion of said chuck to impart a laterally-reciprocating movement thereto, and these double movements of said chuck, cause the rotating cutters $b b$ to so act upon the spoke-blank as to give it the desired spoke-shape, viz, commencing with a circular shape at the end thereof that is held by the centre-chuck, and gradually changing from that to a steadily-widening oval-shape, as its reciprocating, rotary, and longitudinal movements bring it in contact with the series of rotating cutters $b b$.

The said reciprocating movements of the arbor U of the head chuck are produced in the following manner:

A vertical arm, e , rises from its rigid connection with the carriage F' , immediately in the rear of the oval portion g of the arbor U of the head-chuck; and this arm is connected to one of the chuck-supporters p' , by means of a spring, f , as shown in Figure 4.

This spring f possesses a sufficient degree of strength and flexibility to keep the face of the arm e constantly in contact with the face of the oval portion g of the head-chuck, and consequently the rotation of said chuck must necessarily impart a reciprocating movement to the left-hand end of the chuck-carrier F .

Arms $n n$, which descend from their rigid connection with each end of the carriage F' , figs. 1 and 7, carry the rotating horizontal shaft P , and the horizontal rack-bar O , in the positions shown in fig. 1.

The journals of the shaft P work in suitable boxes or apertures, at the lower ends of the supporting-arms $n n$, and the extremities of the rack-bar O are securely bolted to the inner sides of said supporting-arms.

A loose pulley, Q , on the shaft P , is made to turn therewith, by means of a projection from the former working into a longitudinal groove in the latter.

Any lateral movement of the pulley Q is prevented by the arm w , Figure 8, which projects from the frame-post G' , and fits into an annular groove in the elongated hub x of said pulley. Therefore, whilst the pulley Q is being rotated by a band passing from another pulley over the same, the shaft P may be moved longitudinally back and forth within said pulley, as circumstances may require, and as will be hereinafter particularly set forth.

Rotary motion is communicated to the shaft P from the driving-shaft L , by means of a band-connection of said shaft with the parallel shaft N , and by the band D' , which connects the pulley H' , on the shaft N , with the pulley Q on the said shaft P , as shown in fig. 3.

Motion is imparted to the carriage F' in the following manner:

The vertical arm y , which descends from its rigid connection with the under side of the frame-beam A , terminates in an elongated transverse hub or box, e' , which receives and supports the short transverse shaft a , figs. 1 and 3.

Secured to the inner end of the said short shaft a , is

a bevelled-gear wheel *u*, which matches into a bevelled pinion *v*, on the right-hand side of the disk of the pulley *Q*, and which is firmly secured thereto.

To the outer end of the short shaft *a* there is secured a spur-pinion, *d'*, which matches into the toothed wheel *I*, on the outer end of the transverse shaft *t*.

Figure 10 represents the shape and proportions of the transverse shaft *t*. This shaft *t* works in suitable supporters, which descend from their connection with the under sides of the frame-beams *A A'*, and carries a sliding spur-pinion, *u'*, the teeth of which match into the teeth of the rack-bar *O*, when the said pinion is moved to the proper position to produce such a matching connection.

An annularly-grooved projection, from the front side of the pinion *u'*, receives the forks of the angular lever *g*, Figure 11, which is pivoted to the under side of the frame-beam *A*, the vertically-descending portion of said lever forming the handle, by means of which it is operated.

It will thus be perceived that motion is communicated to the carriage *F'* from the shaft *P* through the medium of the bevelled wheels *v u*, the transverse shaft *a*, the pinion *d'*, the toothed wheel *I*, the transverse shaft *t*, and the sliding pinion *u'*, operating with each other in the manner set forth.

Motion is imparted to the arbor *U*, head-chuck, from the shaft *P*, by means of the band *T*, which connects the pulley on the left-hand end of said shaft with the pulley *S* on the chuck-shaft, in the manner represented in Figure 9.

The cutter-head *H* is secured to the projecting end of the shaft *M*, whose bearings are secured to the upper sides of the frame-beams *O O'*.

Motion is communicated to the shaft *M*, from the main shaft *L*, by means of a band and pulley, as shown in the drawings.

The band *D'*, which connects the pulley *H'* on the shaft *N* with the pulley *Q* on the shaft *P*, may be tightened or loosened in the following manner, viz:

The curved lever *R*, which is pivoted to the right-hand side of the frame-post *G'*, carries a flanged pulley, *y'*, on a right-angular termination of the short end of said lever, and in such a position as to embrace the band *D'* a short distance above the pulley *H'*, fig. 3.

A suitably-proportioned weight, *R'*, is secured to the long end of the curved lever *R*.

The elongated tubular box *x'*, which is secured to the left-hand side of the frame-post *G'*, receives the horizontal portion of the angular lever *J*, figs. 1 and 2.

The vertical portion of the lever *J* rises immediately in front of the machine, and the right-angular inward termination of said lever passes to the right through a longitudinal slot in the curved lever *R*, fig. 3.

When the vertical portion of the lever *J* is vibrated so far to the left as to be caught by the spring-catch *r*, fig. 1, that movement of said lever will cause the right-angular termination thereof to elevate the long end of the lever *R*, and thereby loosen the band *D'*, and stop the motion of the shaft *P*, and all the parts that derive their motion therefrom.

A short distance to the right of the cutter-head *H*, a forward projection, *f'*, from the curved bar *a'*, fig. 3, passes under the spoke-blank, when it is being operated upon by the cutters *b b*, and when the said curved bar *a'* is pressed upward by the weighted lever *p*, figs. 1 and 2, through the medium of the crank-shaft *z*, the said projection *f'* serves as an auxiliary support for the said spoke-blank.

An upright portion of the lever *p* is connected with the vertical portion of the lever *J*, by means of the slotted bridle-bar *K*, in the manner shown in fig. 1.

When the lever *J* is thrown into the position where it can be caught by its spring-catch *r*, its connection with the lever *p* causes the said lever to be thrown into the position where it will be caught by its spring-catch

o, as shown in fig. 1; and when the said levers are in that position, the driving-band *D'*, which imparts motion to the shaft *P*, is in a slackened condition, and the auxiliary spoke-blank supporter *f'* is retained in a position below the reach of a spoke-blank; or, in other words, the said levers are in a proper position for a spoke-blank to be secured between the lathe-chucks, and properly adjusted therein, to be operated upon by the rotating cutters *b b*. When this has been done, the front portion of the lever *J* is released from the hold of the catch *r*, which enables the weight *R'*, on the long leg of the lever *R*, to tighten the band *D'*, and impart motion to the shaft *P*, which in turn imparts the requisite movements to the head-chuck *U*, the carriage *F'*, and the chuck-carrier *F*.

Immediately after thus putting the machine in motion, the projection *b'*, figs. 1 and 2, on the carriage *F'*, is brought in contact with the upper end of the spring-catch *o*, and thereby vibrates the same upon its central pivot, which movement of said catch disengages the same from the lever *p*, and causes the weight *p'*, at the extremity thereof, to force upward the auxiliary supporter *f'* against the spoke-blank whilst it is being operated upon by the rotating cutters *b b*.

When the forward movement of the chuck-carrier *F* brings the spoke which is being formed near to its but-end, the lever *J* is so operated as to stop the movement of the said carrier, and also the movements of the arbor *U* of the head-chuck.

As soon as the said stoppage occurs, the action of the rotating cutters *b b* upon the spoke brings its longest diameter into a horizontal position, where it is caught and retained by the action of the spring-actuated detent *d* upon one of the teeth *c*, on the barrel of the head-clutch *U*, as shown in figs. 4 and 6. Then, by taking hold of the cross-head *t* of the said arbor *U* of the head-chuck, and turning the spoke by hand to such positions as to alternately present the sides opposite the shortest diameter of the spoke to the action of the cutters, and at the same time moving forward the clutch-carrier *F*, the required shape of the throat and but-portion of the spoke may be given thereto.

Figure 5 and Figure 5 $\frac{1}{2}$, in the accompanying drawings, represent the shape of a spoke which has been formed in my improved spoke-lathe.

The pulley *S*, on the arbor *U* of the head-chuck, turns loosely in one direction, and is prevented from turning in the opposite direction by the spring-clutch *s'*, figs. 1 and 2, which arrangement enables the spoke to be turned by hand to any desired position for finishing the but-portion thereof without unshipping the band *T*, which imparts motion to the arbor *U* of the head-chuck.

Each of the rails *j' j'*, beneath the carriage *F'*, is divided at the point *y'*, figs. 1 and 2.

The left-hand or shorter portion of each of said rails is permanently secured to its respective supporting-beam *A* or *A'*, and the longer or right-hand portion of each of said rails is pivoted at its right-hand end, and otherwise so arranged as to allow a slight degree of inward vibration to be imparted to the left-hand end of said rails.

Near to the left-hand end of the vibrating portion of the front rail *j'*, there is secured to the inner surface of the frame-beam *A*, a ledge, *k*, whose shape is the reverse or counterpart of that which it is desired to give to the flattened sides of the but-portion of the spoke.

A vertical shaft, *i*, passing down through a transverse slot, fig. 2, in the chuck-carrier *F*, is secured, by means of the spring-box *l*, fig. 4, to the front side of the carriage *F'*.

A roller, *j*, is secured to the lower end of the said vertical shaft *i*, and a handle, *i'*, is secured to the upper end of the same.

The action of a spring in the box *l* ordinarily keeps

the shaft *i* in so elevated a position that the roller *j*, at the lower end thereof, will pass above the ledge *k*, on the inner face of the frame-beam *A*; but by pressing down the said shaft, and turning its handle *i'* toward the front, a catch, within the box *l*, retains the same in the depressed position shown in fig. 4, a position which brings the roller *j*, at the bottom of the shaft *i*, in contact with the afore-mentioned ledge *k* the instant after the left-hand end of the carriage *F'* has passed the left-hand end of the vibrating portion of the rails *j' j'*, and by so doing will move inward the left-hand end of the advancing carriage *F* and the chuck-holder *F*, exactly the proper distance to cause the series of rotating cutters *b b* to turn off the sides of the but-portion of the spoke to the shape represented in fig. 5 $\frac{1}{2}$ of the drawings.

Having thus fully described my improved spoke-lathe,

What I claim therein as my invention, and desire to secure by Letters Patent, is—

1. The combination of the carriage *F'* with the chuck-carrier *F*, the rack-bar *O*, and the shaft *P*, substantially in the manner herein set forth.

2. The peculiar arrangement of parts for communicating the required longitudinal movements to the carriage *F'*, and the respective operating-parts that are combined therewith, viz, the bevel-wheel *v*, secured to the loose pulley *Q*, on the shaft *P*, and gearing with the bevel-wheel *u*, on the transverse shaft *a*, the pinion *a'*, on the shaft *a*, gearing with the toothed wheel

I, on the transverse shaft *t'*, the sliding pinion *u'*, on the shaft *t'*, whose teeth can, by the action of the hand-lever *g*, be made to gear with the teeth of the rack-bar *O*, all substantially in the manner herein described.

3. The herein-described combination of parts by which I am enabled to impart such a compound series of movements to a spoke-blank, that a series of rotating cutters, *b b*, is enabled to reduce said blank to the desired spoke-shape, viz, commencing with a circular shape at the outer end of the spoke, and changing from that to a gradually-widening oval shape toward the but-end of the same, all substantially as herein set forth.

4. The herein-described combination of parts, by which I am enabled to impart the requisite movements to the spoke to enable the rotating cutters *b b* to give the desired shape to the but-portion thereof, (shown by fig. 5 $\frac{1}{2}$), all substantially in the manner herein set forth.

5. The combination of the hand-lever *J* with the weighted lever *p*, the shaft *z*, and the auxiliary spoke-blank holder *a' f'*, fig. 3, substantially in the manner and for the purpose herein set forth.

The foregoing specification of my improved spoke-lathe, signed this 30th day of September, 1868.

ISAAC S. ROLAND.

Witnesses:

Z. C. ROBBINS,
EDM. F. BROWN.